

**sigma**

**User Manual**

# Contents

<b>Introduction</b>	<b>3</b>
UE Warranty	3
Non-UE Warranty	5
Conformity	8
Specifications	9
IDEX / FFF Technology	10
Safety	10
Safety Signage	12
<b>Setting Up Your Printer</b>	<b>13</b>
Unpacking	13
Contents	14
Preparing Your Printer	15
<b>* Switching On Your Printer For The First Time</b>	<b>20</b>
Loading The Filament	20
Calibrating Your Printer	21
First Printing	23
<b>Starting Out With Cura-Bcn3d</b>	<b>24</b>
Downloading And Installing Cura	24
First IDEX Printing	26
Cura Updates	27
<b>Functionalities</b>	<b>30</b>
<b>Filament</b>	<b>32</b>
<b>Maintenance Plan</b>	<b>34</b>
<b>Bcn3d Technologies Technical Assistance Services</b>	<b>35</b>
<b>Diagram Of The Bcn3d Sigma</b>	<b>36</b>
<b>Warranty, Returns And Replacement Policy</b>	<b>38</b>
<b>Terms And Conditions Of Service</b>	<b>39</b>
<b>Open Source</b>	<b>40</b>

\*You can see Switching On Your Printer For The First Time Section on our youtube channel:  
<https://www.youtube.com/playlist?list=PL8iOVmTsyvGRYhiB4ykxxzcl1gnakOReg>

# Introduction

## EU Warranty

---

### Technical Support

For any questions or problems with BCN3D Products, please contact us at:

c/ Esteve Terrades, 1  
Edifici RDIT del PMT, 2a Planta 216  
08860 Castelldefels, Barcelona (España)  
email: sat@bcn3dtechnologies.com  
Tel: +34 934137088

---

Fundació Privada Centre CIM  
c/ Llorens i Artigas, 12  
08028 Barcelona (España)  
Tel. +34 934017171

### List of Consumable components

This document lists the Consumable components that, for its natural deterioration, are excluded from the Warranty: **BCNozzle (Hotend), Bowden Tube, Hotbed Glass, Filament Spools, 3DLAC, Printed Parts.**

Fundació Privada Centre CIM ("Fundació CIM") grants this Warranty to the BCN3D brand Product users.

This Warranty is only valid in the country where the Product has been purchased originally, as long as it is member of the European Union, Iceland, Norway, Switzerland, Liechtenstein or Turkey. Otherwise, review the Warranty for non EU countries.

Fundació CIM guarantees that, within the Warranty Period, Fundació CIM or an authorized service company will correct, in a reasonable commercial time, the claims related with the non-conforming Product according to the following clauses.

## Warranty Period

The Warranty Period starts when the Product is first delivered to the end-user.

The Warranty period lasts twenty-four (24) months. Both the parts that suffer wear and tear due to the normal operation of the Product and the "Consumable" elements are not covered by this Warranty.

The present Warranty is invalidated in case of incurring in any of the cases exposed in the Exclusions chapter.

In case of resale, repair or substitution of the Products the Warranty is not extended. The repaired or substituted parts are covered until the end of the Warranty Period or during six (6) months, depending on which date is later.

# EU Warranty

---

## How to get Warranty Service

In case of non-conformity with the Product:

- 1** Notify the seller before the end of the Warranty Period
- 2** Supply all the information to Fundació CIM or to the authorized service company about the nature of the claim in the period of two (2) months since its detection and never after the end of the Warranty Period.
- 3** Supply the original proof of purchase, which includes the Product serial number

In case of doubt, contact the Fundació CIM Technical Assistant Service ("TAS") (sat@bcn3dtechnologies.com) or the authorized service company

## Claim handling

- 1** The remedy of the non-conforming Product is solely determined by Fundació CIM or the authorized service company within a reasonable commercial time.
- 2** The amendment may consist in the repair, part replacements or total substitution of the Product, depending on each situation and disposed by Fundació CIM or the authorized service company (unless the current legislation states it otherwise).
- 3** Fundació CIM or the authorized service company, depending on which handles the claim, bears the shipping costs, if needed.
- 4** Fundació CIM or the authorized service company, depending on which handles the claim, bears the repair, parts replacement or Product substitution costs.
- 5** All damaged, defective or replaced parts or Products

become the property of Fundació CIM or the authorized service company.

## Exclusions

This Warranty does not cover:

- 1** Physical damage caused by an inappropriate transport (not using the official packaging) or handling (including unlimitedly the damages caused by sharp or cutting elements, bending or compressing parts or fall of the Product).
- 2** The normal wear and tear occurred for the product normal use, including unlimitedly the wear of moving parts, control panels or elements interacting with the product operation.
- 3** The damages inflicted by the non-compliance of the Maintenance Plan specified in the Product User Manual.
- 4** Malfunctions or damage caused by modifications, alterations or repairs by any individual or company not authorized by Fundació CIM. The Consumable replacements are excluded of this point.
- 5** Damage caused by power grid failures
- 6** Damage caused by abuse, misuse, accidents or neglect using the Product.
- 7** Resulting damages of exposing the Product to floods, fire, humidity, spillage of food or chemicals, corrosion, oxidation, extreme weather conditions or any other external agent.
- 8** Damages caused by the use of software non recommended by Fundació CIM.
- 9** Damages caused by the use of printing materials non recommended by Fundació CIM .
- 10** The components considered as Consumables, numbered in the annexed document.

# EU Warranty

---

## Limitations and Disclaimers

This Warranty is the end user's sole and exclusive remedy against Fundació CIM and the sole and exclusive responsibility of Fundació CIM to defects in their Products. Therefore, this Warranty supersedes any other warranties issued by Fundació CIM, either oral or written in any form.

However, this Warranty does not limit either the consumer user rights specified in the legislation nor the the rights against the seller, also defined in the legislation.

Fundació CIM waives all liability for any loss of businesses, loss of contracts, loss of benefits, loss of savings, increase of costs or expenses due to the use of any of its Products. Likewise, Fundació CIM refuses any indirect, incidental, collateral damage by the use of its Products.

## Non-EU Warranty

---

Fundació Privada Centre CIM ("Fundació CIM") grants this Warranty to the BCN3D Technologies brand Product users.

This Warranty is only valid in the country where the Product has been purchased originally, as long as it is not member of the European Union, Iceland, Norway, Switzerland, Liechtenstein or Turkey. Otherwise, check the Warranty for EU countries.

The present Warranty is invalidated in case of incurring in any of the cases exposed in the Exclusions chapter.

In case of resale, repair or substitution of the Products the Warranty is not extended. The repaired or substituted parts are covered until the end of the Warranty Period or during six (6) months, depending on which date is later.

Some states do not allow limitations on how long an implied warranty lasts, so the above limitation may not apply to you.

## Warranty Period

The Warranty Period starts when the Product is first delivered to the end-user.

The Warranty period lasts twelve (12) months. Both the parts that suffer wear and tear due to the normal operation of the Product and the "Consumable" elements are not covered by this Warranty.

## How to get Warranty Service

In case of non-conformity with the Product:

- 1 Notify the seller before the end of the Warranty Period

# Non-EU Warranty

---

**2** Supply all the information to Fundació CIM or to the authorized service company about the nature of the claim in the period of two (2) months since its detection and never after the end of the Warranty Period.

**3** Supply the original proof of purchase, which includes the Product serial number

In case of doubt, contact the Fundació CIM Technical Assistant Service ("TAS") (sat@bcn3dtechnologies.com) or the authorized service company.

## Claim handling

**1** The remedy of the non-conforming Product is solely determined by Fundació CIM or the authorized service company within a reasonable commercial time.

**2** The amendment may consist in the repair, part replacements or total substitution of the Product, depending on each situation and disposed by Fundació CIM or the authorized service company (unless the current legislation states it otherwise).

**3** Fundació CIM or the authorized service company, depending on which handles the claim, bears the shipping costs, if needed.

**4** Fundació CIM or the authorized service company, depending on which handles the claim, bears the repair, parts replacement or Product substitution costs.

**5** All damaged, defective or replaced parts or Products become the property of Fundació CIM or the authorized service company.

## Exclusions

This Warranty does not cover:

**1** Physical damage caused by an inappropriate transport (not using the official packaging) or handling (including unlimitedly the damages caused by sharp or cutting elements, bending or compressing parts or fall of the Product).

**2** The normal wear and tear occurred for the product normal use, including unlimitedly the wear of moving parts, control panels or elements interacting with the product operation.

**3** The damages inflicted by the non-compliance of the Maintenance Plan specified in the Product User Manual.

**4** Malfunctions or damage caused by modifications, alterations or repairs by any individual or company not authorized by Fundació CIM. The Consumable replacements are excluded of this point.

**5** Damage caused by power grid failures

**6** Damage caused by abuse, misuse, accidents or neglect using the Product.

**7** Resulting damages of exposing the Product to floods, fire, humidity, spillage of food or chemicals, corrosion, oxidation, extreme weather conditions or any other external agent.

**8** Damages caused by the use of software non recommended by Fundació CIM.

**9** Damages caused by the use of printing materials non recommended by Fundació CIM.

**10** The components considered as Consumables, numbered in the annexed document. Some states do not allow the exclusion of incidental or consequential damages, so the above limitation or exclusion may not apply to you.

# Non-EU Warranty

---

## Limitations and Disclaimers

This Warranty is the end user's sole and exclusive remedy against Fundació CIM and the sole and exclusive responsibility of Fundació CIM to defects in their Products. Therefore, this Warranty supersedes any other warranties issued by Fundació CIM, either oral or written in any form.

However, this Warranty does not limit either the consumer user rights specified in the legislation nor the the rights against the seller, also defined in the legislation.

Fundació CIM waives all liability for any loss of businesses, loss of contracts, loss of benefits, loss of savings, increase of costs or expenses due to the use of any of its Products. Likewise, Fundació CIM refuses any indirect, incidental, collateral damage by the use of its Products.

# Conformity

---

The CIM Private Foundation Centre declares that the BCN3DSigma printer complies with the essential requirements and any other applicable or mandatory provisions of the Directives.

It complies with the essential requirements of the European Directives:



**2006/42/EEC** Machinery Directive

**2006/95/EEC** Low Voltage Directive

**2004/108/EEC** Electromagnetic Compatibility Directive (EMC)

**2011/65/EU** Restrictions on the use of hazardous substances in electrical and electronic equipment (RoHS)

The BCN3DSigma printer has been manufactured in compliance with the following harmonised standards, and consequently conforms to the essential requirements established by the Directives:

**2006/42/EEC** UNE-EN ISO 12100:2012; UNE-EN ISO13732-1 :2008; EN ISO 7010:2012

**2006/95/EEC** UNE-EN 60204-1; UNE-EN 60947-3:2009

**2004/108/EEC** UNE-EN 55022:2011; UNE-EN 55024:2011; UNE-EN 61000-4-3-2:2007

Changes / modifications not approved by the responsible party could void the user's authority to operate the equipment.

This equipment has been tested and found to comply with the limits for a Class B digital device, pursuant to part 15 of the FCC Rules. These limits are designed to provide reasonable protection against harmful interference in a residential installation. This equipment generates, uses and can radiate radio frequency energy and, if not installed and used in accordance with the instructions, may cause harmful interference to radio communications.

However, there is no guarantee that interference will not occur in a particular installation. If this equipment does cause harmful interference to radio or television reception, which can be determined by turning the equipment off and on, the user is encouraged to try to correct the interference by one or more of the following measures:

- Reorient or relocate the receiving antenna.
- Increase the separation between the equipment and receiver.
- Connect the equipment into an outlet on a circuit different from that to which the receiver is connected.
- Consult the dealer or an experienced radio/TV technician for help.

Fundació Privada Centre CIM

Llorens i Artigas, 12 08028 Barcelona.

Tel: +34 934017171

[www.fundaciocim.org](http://www.fundaciocim.org)

## Specifications

---

Technology	Independent dual extruder (IDEX)
Manufacturing technology	Fused filament fabrication (FFF)
General dimensions	465 mm x 440 mm x 680 mm (fully assembled)
Weight	15 kg (without filament spools)
Printing volume	210 x 297 x 210 mm
Number of extruders	2
Layer height	0.05-0.35 mm (with a standard 0.4 mm nozzle)
Positioning resolution	Axis X: 0.0125 mm Axis Y: 0.0125 mm Axis Z: 0.001 mm
Operating temperature	15° C -35° C
Maximum extruder temperature	290° C
Max. temperature of heated bed	100° C
Filament diameter	3 mm
Compatible material	PLA ABS PVA TPE (with 0.6 mm nozzle) HIPS Composites (con boquilla 0,6mm)
Electronics	BCN3D Electronics v1.0
Connectivity	SD card (autonomous operation), USB
Firmware:	BCN3D Sigma - Marlin
Compatible files	gcode
Software preparation files	Cura-BCN3D, Slic3r, Simplify3D,...
Power supply	AC 84–240 V, AC 3.6-1.3A, 50–60 Hz
Electrical energy consumption	240W

## IDEX / FFF technology

---

The BCN3D Sigma is a 3D printer which uses fused filament fabrication (FFF) technology, which manufactures objects by depositing molten material in a series of layers. Objects are created using a digital model of the object, which is sliced into thin layers. When printing the extruder print head moves along the axis to deposit the material for one layer at a time, before moving slightly upwards to begin printing a new layer. This process is repeated until the object has been completed.

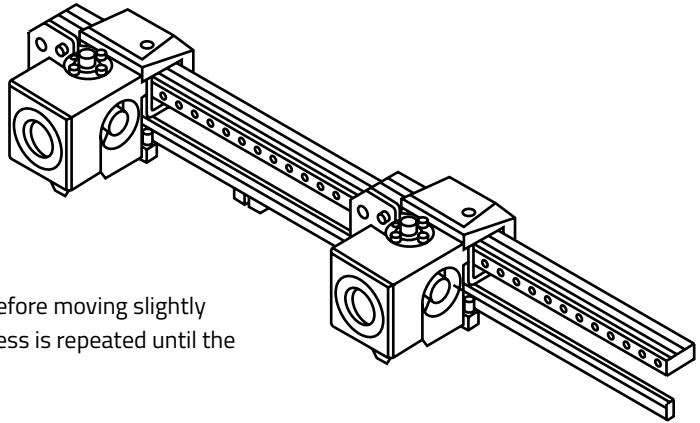

The IDEX 3D printer has independent extruders which offer users the ability to print multi-coloured objects with multiple materials. The two extruders are controlled independently, so that when one extruder is not being used it can be kept away from the printing area to prevent the plastic from oozing onto the object and spoiling the final result. Thanks to this system it is possible successfully combine the properties of two different filaments and print highly-detailed complex objects.

## Safety

---

To avoid potential residual risks the user should read and understand the following safety measures (you are strongly advised to read this before using the machine).

To highlight the areas where extra care should be taken, safety alert stickers have been affixed to the relevant parts of the machine to warn the user of potential hazards.

Any modifications made to the machine without the manufacturer's approval will invalidate the product's Declaration of Conformity (CE) and warranty.

Consequently, the Fundació CIM and BCN3D Technologies ARE EXEMPT FROM ANY LIABILITY IF THE USER DOES NOT FOLLOW THE INSTRUCTIONS FOR USE:



**Very important. As with any other appliance, do not touch the terminals of the mains, the switch, or the power supply. There is a risk of electrocution. The other cables of the machine operate at 24V and there is no risk whatsoever.**

**Connect the machine to an electrical outlet according to the current legislation.**

**Do not connect or disconnect any device and/or electrical connector when the machine is connected to the power supply.**

**Keep all of your body and all objects away from the moving parts of the machine when they are moving.**

**Do not touch the hot parts (heated bed and hot-ends) when the machine is switched on, and wait 15 minutes after it has been switched off before touching them.**

**Handle the glass printing surface with care. Make sure it is not dropped or hit with anything as this could seriously damage it.**

**The printing materials are not innocuous and emit toxic fumes. Always print in open or well-ventilated spaces and use a protective mask.**

**Do not breathe closer than 25 cm from the extruder head when printing.**

**Supervise the printer while it is printing to make sure it is working properly.**

**In the event of emergency, stop the machine immediately by pressing the ON button, and disconnect the power supply.**

**This device is not a toy. It should only be used by minors under 16 under the supervision of an adult.**

**The spatula is a dangerous tool that can cause injuries. Use it only to remove plastic rests when running the calibration assistant.**

# Safety signage

The following stickers have been affixed to the printer to warn users about the hazardous areas of the machine, and actions which are not recommended as they will stop the machine from working properly.

1 Pictogram: Danger. Hot surface.



2 Pictogram: Danger. Will cause burns.



3 Pictogram: Risk of trapped hand/ finger.

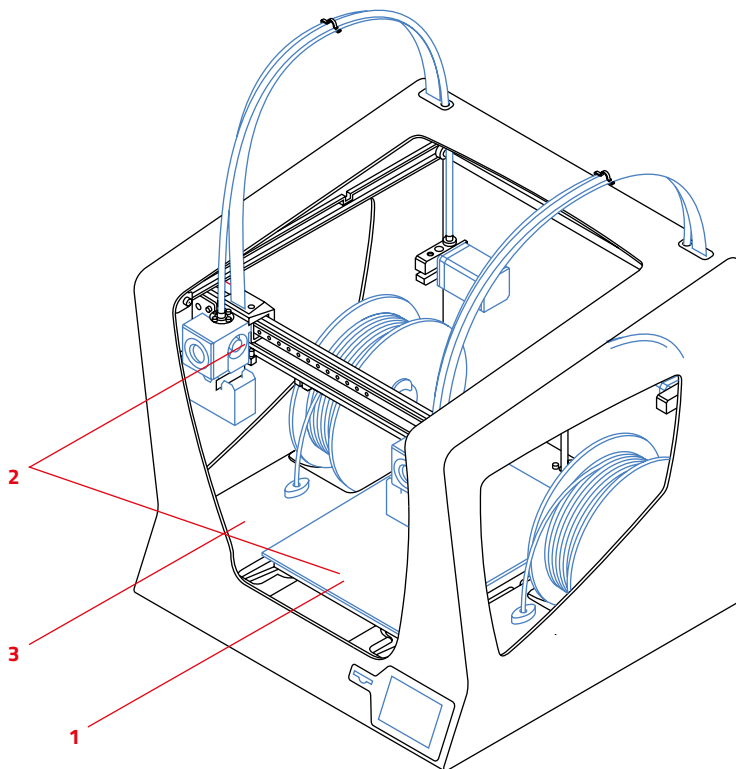

# Setting up your printer

## Unpacking

The BCN3D Sigma is delivered in a well-secured cardboard box which measures 550 x 660 x 570mm. We recommend you to follow the steps below in order to unpack your 3D printer correctly:

1.

Open the box by the top and remove the foam, which contains the box with the quick start guide and printer's accessories.

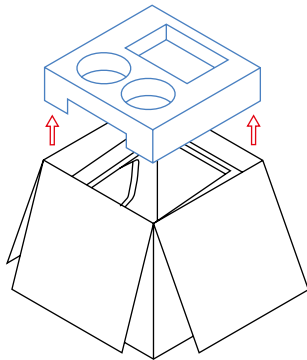

2.

Lift the printer out of the box, holding it by the back zone (red marked area). It is recommended to do it with someone else. Place the machine on a flat surface which is large enough to allow you to operate it.

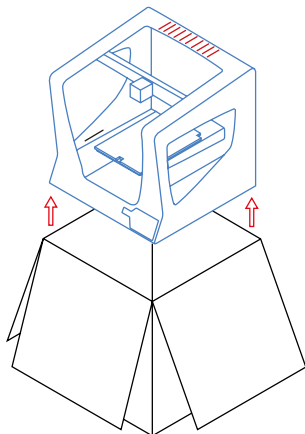

3.

Remove the foam which is inside the printer, between the printing surface and the blue covus

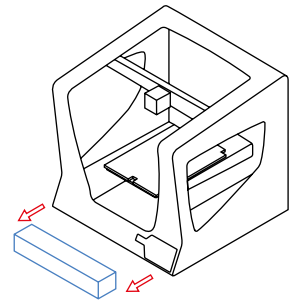

4.

Use a strong scissors to remove the three zip ties that block the movement of the axes. Make sure you remove one zip tie for each extruder carriage as well as the tie that fastens the whole axis to the back bar.

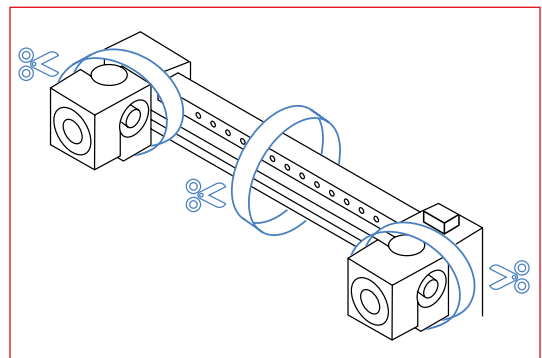

We recommend you to keep the cardboard box to transport or store the printer.

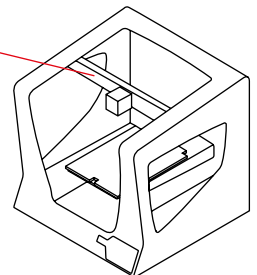

# Contents

---

BCN3D Sigma

---

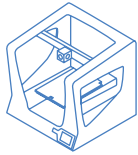

Quick start Guide

---

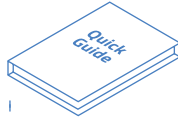

2 bowden tubes

---



4 Flat cable clips

---

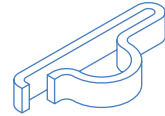

2 Spool holders

---

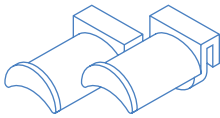

2 cleaning rubbers

---

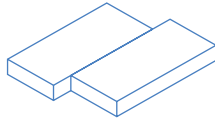

Glass

---

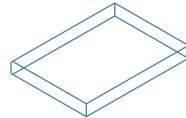

Power Cable

---

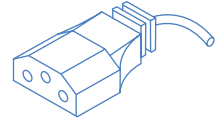

SD card

---

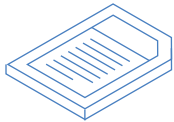

USB cable

---

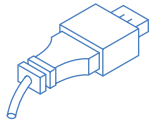

2 PLA spools

---



Spatula

---



Cross-head screwdriver

---

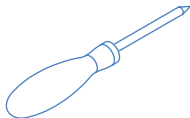

3 hex keys

---

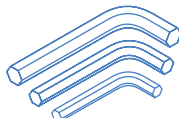

Pliers

---

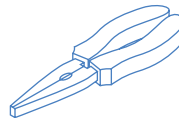

Nylon cable

---

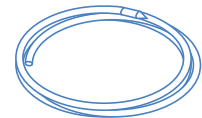

Laquer

---



Sample piece

---

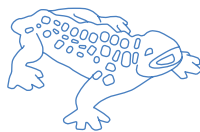

Warranty

---

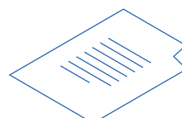

## Preparing your printer

---

In order to ensure the safe packaging and transport of your printer some of the components have been sent unassembled. Before starting to print with the BCN3D Sigma printer you need to assemble them in order to complete the setting up process.

If you have any queries while assembling the machine, please contact BCN3D Technologies' technical services.

Follow the steps below to prepare the printer:

**1.**

Place the glass on the platform, making sure the magnets fit in the slots

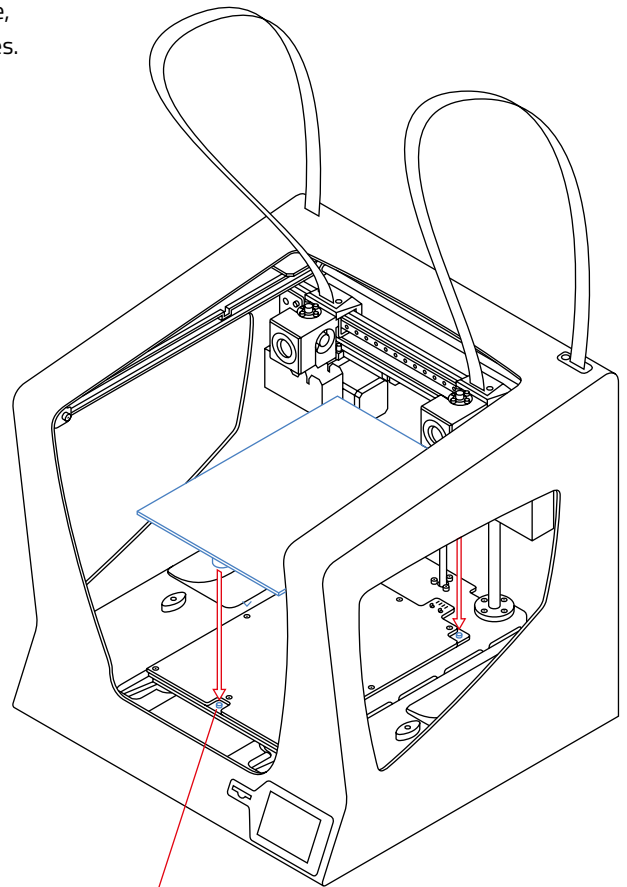
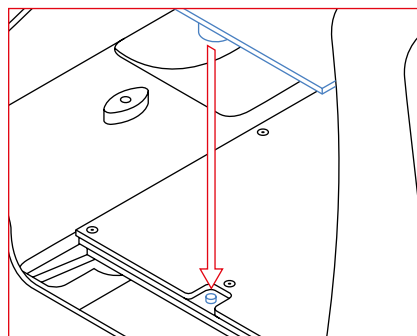

## Preparing your printer

---

**2.**

Place the spool mounts in the spools.

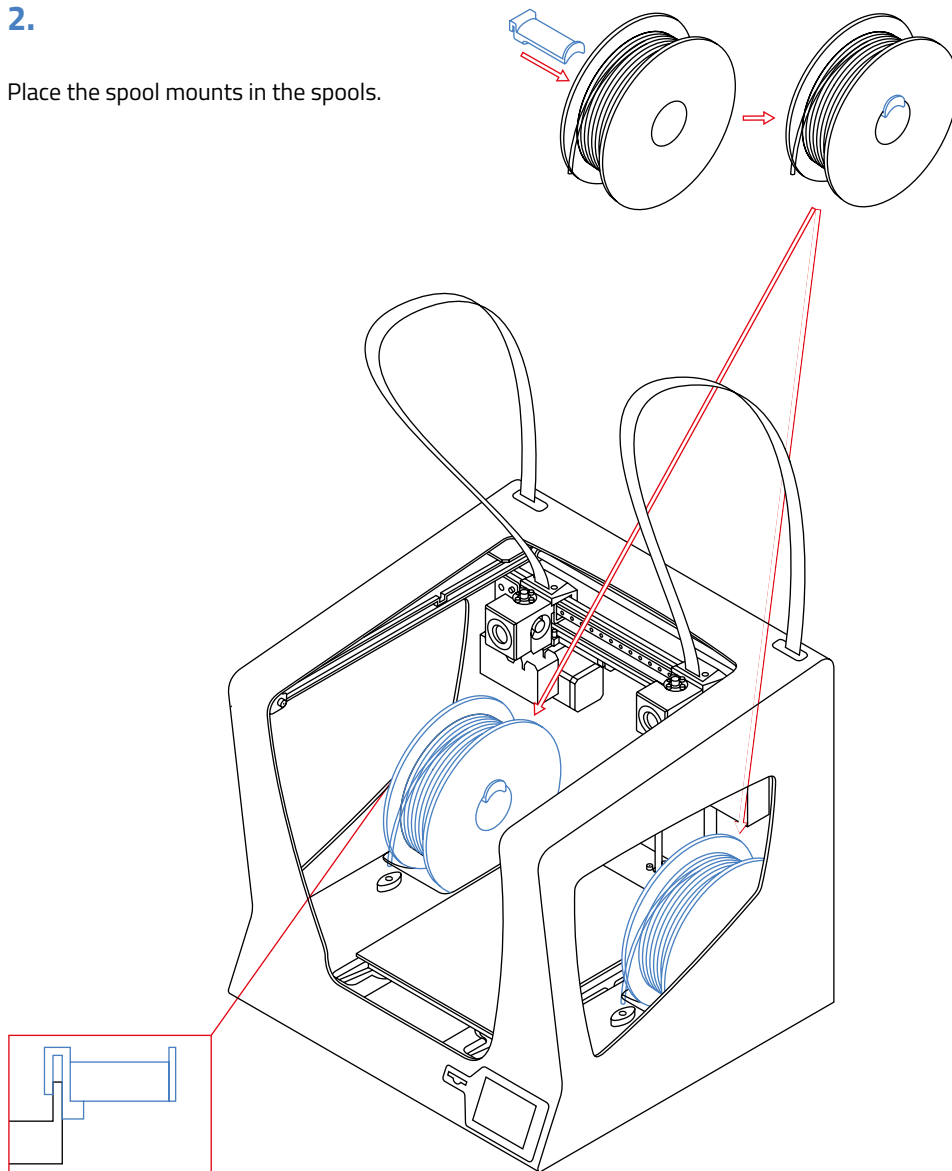

**3.**

Slot the spools with the mounts into the appropriate spaces.

## Preparing your printer

---

4.

Pull the guide rails of the hot-ends forwards by hand.

5.

Insert the teflon tube as far as it can.

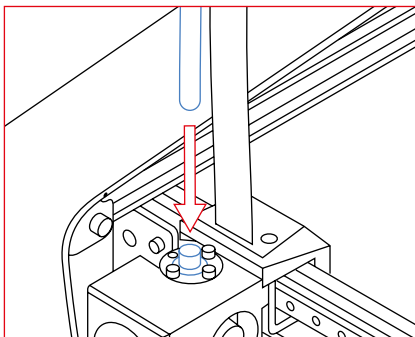
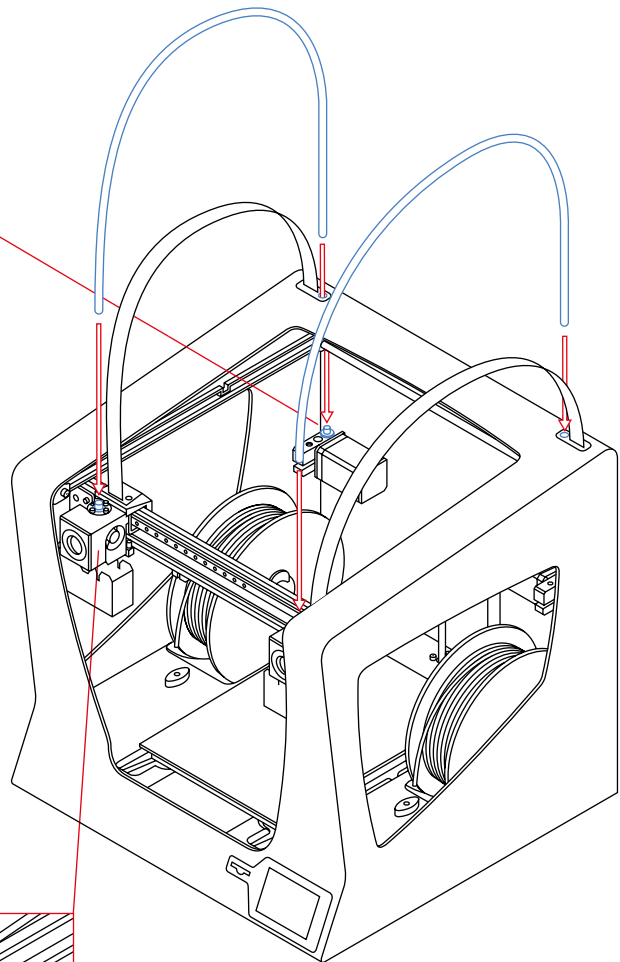
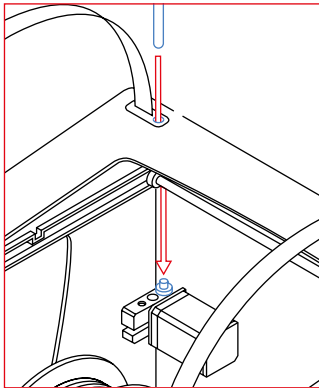

6.

Insert the other end into the hot-end hole.

## Preparing your printer

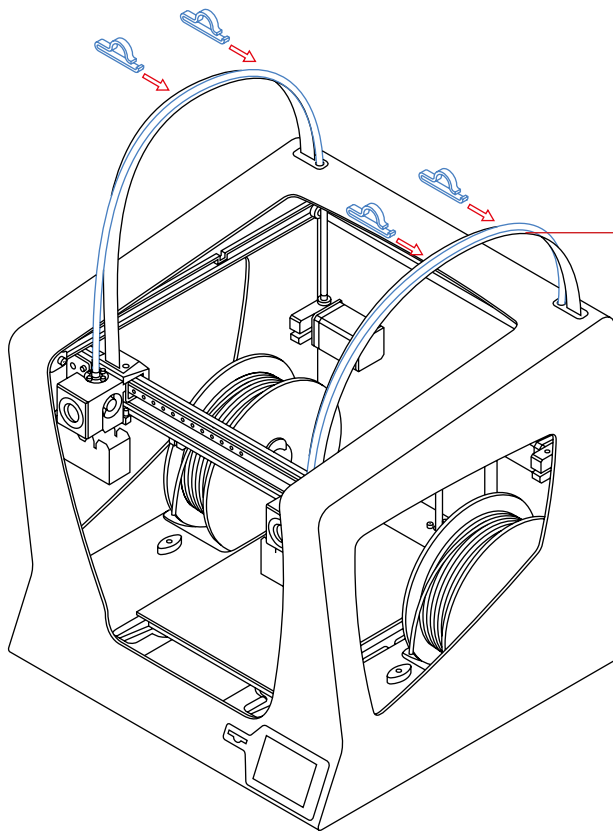

7.

Fasten the filament tube and cable together with the clips.

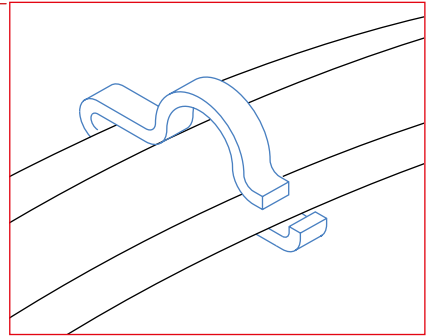

8.

Insert the purge tabs into the side chambers.

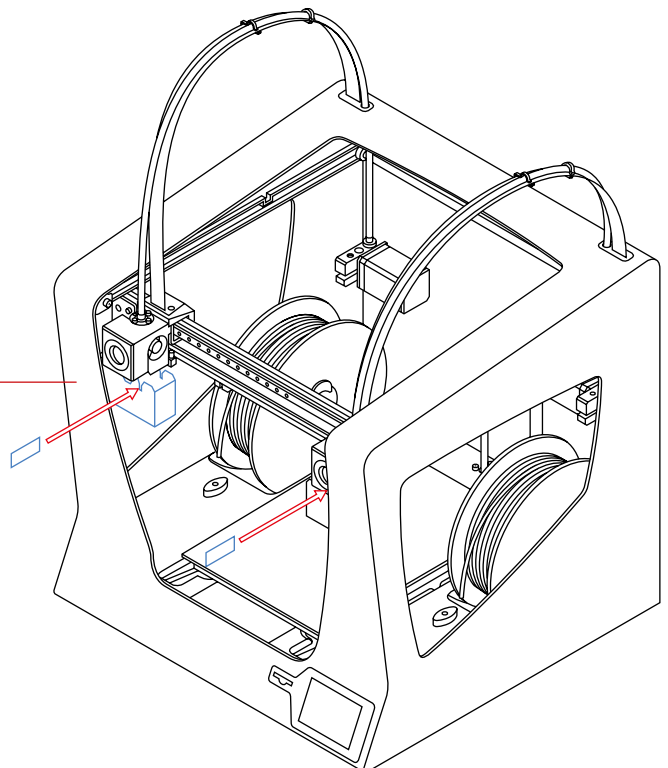
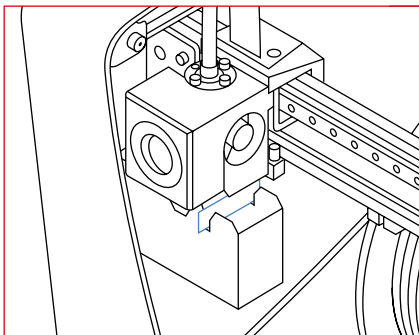

## Preparing your printer

---

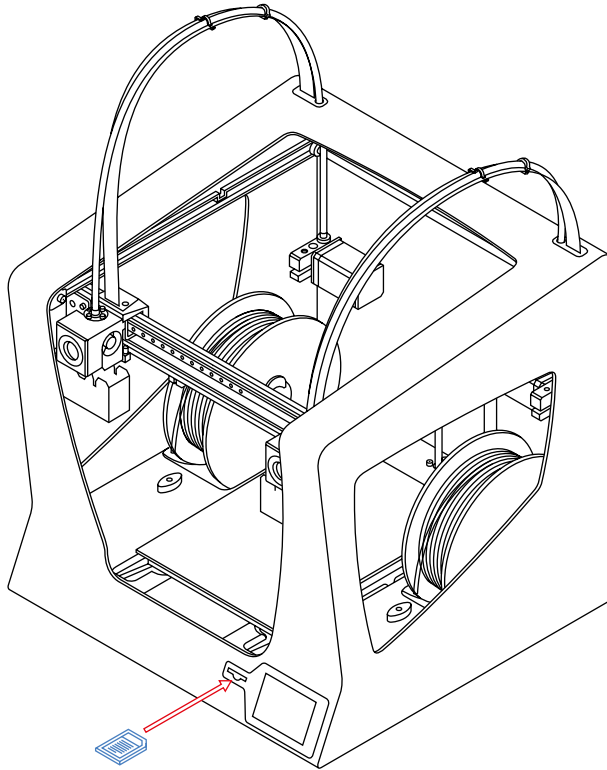

**9.**

Connect the power supply cable at the rear.

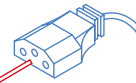

**10.**

Insert the SD card into the reader.

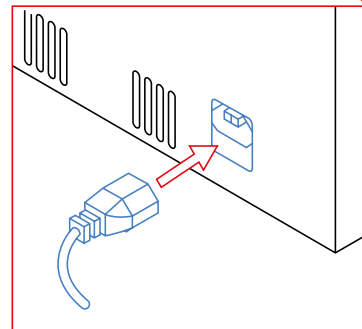

# Switching on your printer for the first

## Loading filament

---

The first thing you have to do after switching on the BCN3DSigma for the first time is to load the two filament spools that were in the box.

To do this you need to follow the onscreen instructions. First, load the filament into the left extruder, and then load the filament into the other extruder.

1. Press the ON button

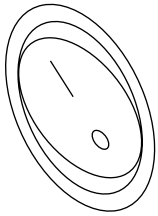

2. Main menu

Press *utilities*



3. Utilities

Press *filament*



4. Filament options

Press *insert filament*

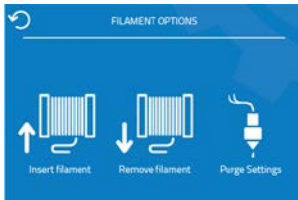

4. Select material

Choose *material spool*

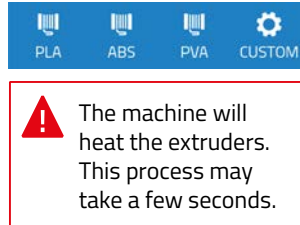

5. Select extruder

Choose *extruder*



6. Follow instructions

Press *insert filament*

7. Repeat this process with the

other extruder.

You can see Switching On Your Printer For The First Time Section on our youtube channel:  
<https://www.youtube.com/playlist?list=PL8iOVmTsyvGRYhiB4ykxxzcl1gnakOReg>

## Calibrating your printer

---

The printer was calibrated and tested after manufacture, but it may need a final adjustment after having been transported.

The first step is to calibrate the level of the printing surface. The extruder head takes a series of measurements and then, depending on the results, displays the corrections which are needed. These are made by turning the levelling wheels underneath the printing platform.

Next the relative positions between the extruders are calibrated in the three directions: Z, X and Y. When calibrating the Z-axis the printing surface moves progressively closer to the nozzle to ensure the molten plastic will be extruded at the correct distance. In order to avoid damaging the glass, you should place a calibration sheet on the printing surface and then bring the nozzle closer to it in very small increments.

This calibration sheet will be used to determine the distance between the nozzle and the hot bed.

In the 7th step of the calibration process, place the sheet on the hot bed just below the nozzle. Every time the button "up" is pressed, the surface moves toward the nozzle. Doing a swinging movement to the direction indicated by the arrows, slowly raise the surface until you feel a slight contact with the nozzle.

Warning: this step can break the glass base if this one is too close to the nozzle.

Adjust the distance between the nozzle and the printing surface until the paper is blocked. You will know that is correct if you try to push the paper and it bends, and if you pull it, it slides.

After the calibration has been completed, the two heads will draw some lines on the surface to verify that the process has been performed correctly. If the lines do not print, or do not adhere properly to the surface, the process can be repeated by pressing the REDO button. In this case you should remove any old material from the earlier printing before repeating the test.

While calibrating the X and Y axes the BCN3D Sigma prints some lines with both extruders to check for misalignments. Choose the two pairs of lines that coincide the best

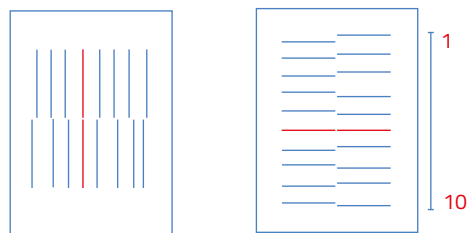

*For X the first line is the one on the left and for Y the one at the top*

If none of the lines coincide you should select the point at which they are closest, and repeat the process (Important! Remove any old material from the earlier printing before repeating the test). If the lines have not printed properly, you can repeat the process by selecting the REDO option.

# Calibrating your printer

## 1. Main menu

Press utilities

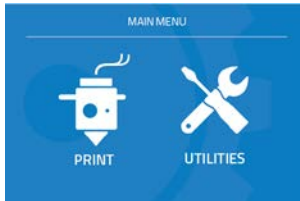

## 2. Utilities

Press calibrate



## 3. Calibration

Press full calibration



## 4. Hot bed leveling



## 5. Turn calibration screw as indicated by the display



## 6. Clean the nozzle

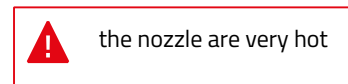

## 7. Use the calibration sheet

## 8. The printer will print a test to validate the above process

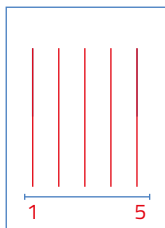

## 9. Z Axis calibration

Choose the best of 5 lines



## 10. The printer will print vertical lines

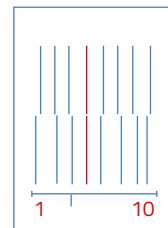

## 11. Choose the couple best aligned couple of lines



## 12. The printer will print horizontal lines

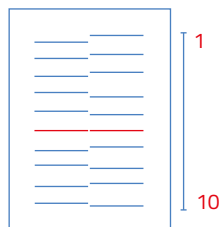

## 13. Choose the couple best aligned couple of lines



## Frist printing

---

After the calibration process has been completed, you can access the printing menu. The first object you will print with the BCN3D Sigma is the Draudi figure, as it will allow you to check that everything is working properly and you are now ready to start printing your own objects. Make sure that the glass is clean, and apply a small amount of adhesive lacquer to get the best results.

# Starting out with Cura-BCN3D

Although BCN3D Technologies printers are compatible with many different G-Code software generators, we recommend using the Cura version that has been developed by BCN3D Technologies.

Cura is open source software that adapts to the new IDEX system very well. Like other G-Code software generators, Cura slices 3D models into layers, where the perimeters and infill of the object are clearly defined.

To provide a better printing experience, BCN3D Technologies's version of Cura includes some changes which have been made to Cura's interface and functionalities. These changes to the software have enabled us to achieve a better performance.

## Downloading and installing Cura

If you already have an earlier version of Cura that was not developed by BCN3D Technologies, we recommend you uninstall it. Next you should visit BCN3D's GitHub repository, where you will find all the Cura-BCN3D versions and updates.

<https://github.com/BCN3D>

Depending on which operating system you use, click on one of the links you can see in the photo.

## Cura-BCN3D for Windows

### 1. Download ZIP



### 2. When the download is completed you must decompress the folder and execute the Cura-BCN3D.exe file.

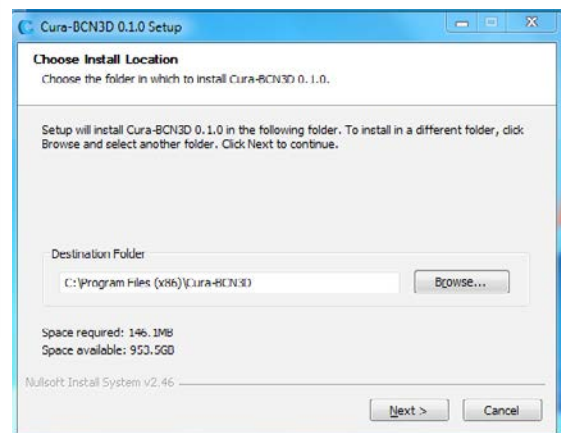
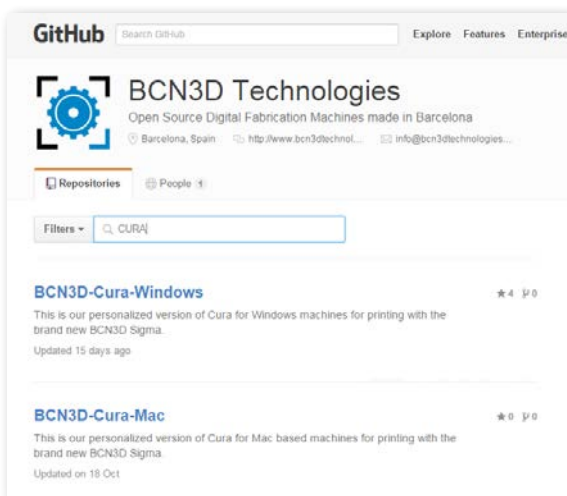

# Downloading and installing Cura

3. Next follow the instructions of the Setup Wizard.



4. If it is the first time you have installed the Cura software, the First-time-run Wizard will appear onscreen:

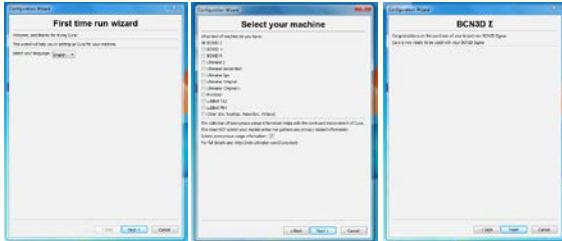

5. Select BCN3D Sigma from the list of printers, and close the Wizard.

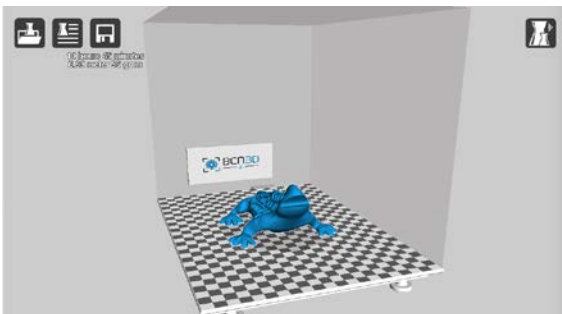

## Cura-BCN3D for Mac

1. Download ZIP



2. When the download is completed you must decompress the folder and execute the Cura-BCN3D.dmg file.



3. When the file is opened a new window will appear, asking for the programme to be installed in the applications.



# Downloading and installing Cura

4. If it is the first time you have installed the Cura software, the First-time-run Wizard will appear onscreen:



5. Select BCN3D Sigma from the list of printers, and close the Wizard.

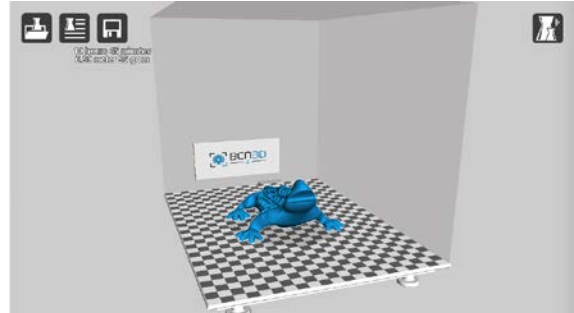

# Frist IDEX printing

1. Open the Cura-BCN3D programme after downloading and installing it.

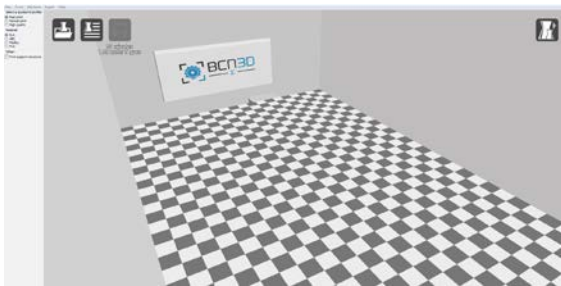

3. Right-click on one of the two objects of the model. Click on the Dual Extrusion Merge option.

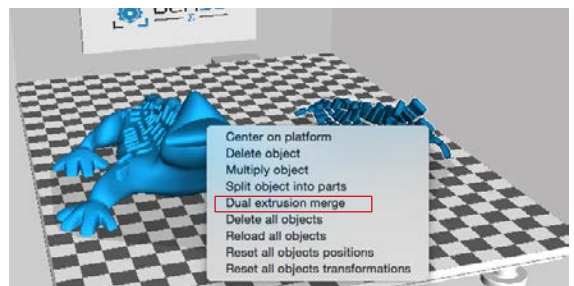

2. Click on File. Load Draudi profile and select the \*.STL format files to be printed. After you have done this, the Draudi object will appear in two parts.

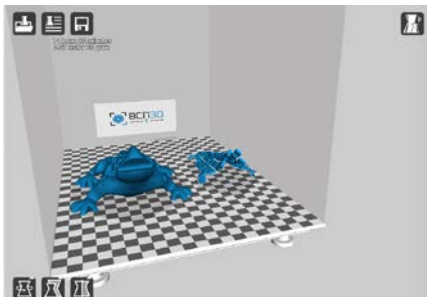

4. The figure should now appear as a single model in two different colours. This process may take a few seconds.

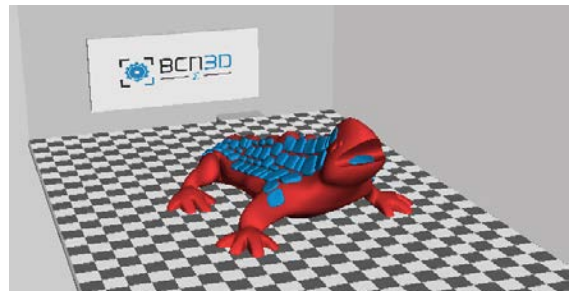

## Frist IDEX printing

5. You must now select the settings, depending on the materials to be used and the desired quality. To do this click on File > Open Profile, or on the icon, and choose the settings. IDEX folder contains dual extruder configurations while MEX folder contains mono extruder configurations.

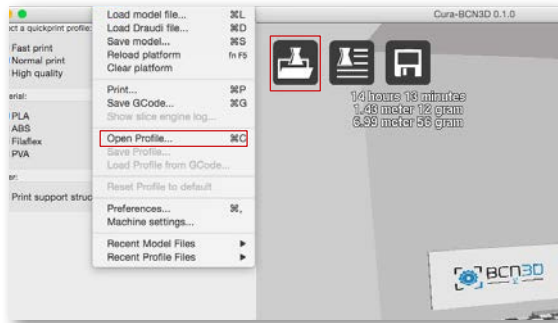

6. When you want to start printing insert an SD card into the computer. The programme will detect the card when it is inserted, and the Disc icon will be replaced by an SD card with the Toolpath to SD option. After saving the file in the SD card, the Eject Card option will appear.



7. You must insert the SD card into the printer in order to print. After inserting the card you should select Print in the main menu, as well as the file you want to print.



## Cura Updates

At BCN3D Technologies we want you to have a great printing experience, and to achieve this we are continually working to create new software and firmware versions for our printers. These updates are made available at BCN3D's GitHub once our developers think that they are ready for release to the general public. The new versions can either be manually downloaded or downloaded from Cura-BCN3D.

### Software updates

The first time you install Cura-BCN3D you must go to the GitHub repository and download the most recent version. After the programme has been installed it will

automatically look for updates, and notify you if a new version of the programme is available.



If you decide to update the software, a page will open showing the GitHub repository where you can see the changes made to the programme, and download the new version.

# Cura Updates

## Firmware updates

1. Make sure your BCN3D Sigma is connected to the computer
2. Click on Machine > Check for firmware updates.

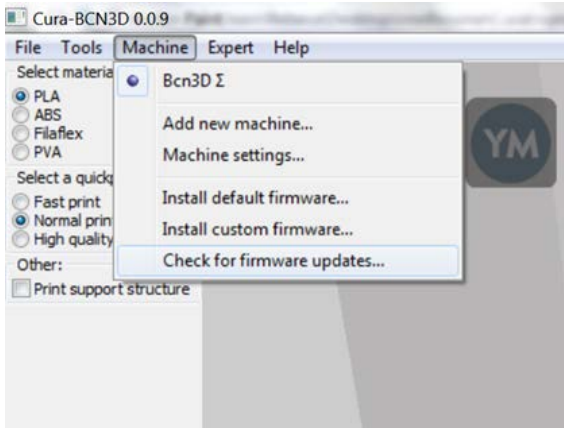

3. Next an automatic updater will appear, where you should select BCN3D Sigma from the list of printers. Although all BCN3D Technologies' printers appear in the list, at the moment only BCN3D Sigma firmware updates are available.



4. Click on Upgrade Firmware.



5. If you want to check whether the printer's firmware is up-to-date you should connect the printer to the computer with the USB cable, and then click on Connect Printer.



# Cura Updates

6. While the printer is connecting the updater will display the Connecting to Machine connection status. Once the machine is connected the ball icon indicating status will change to OK in green.

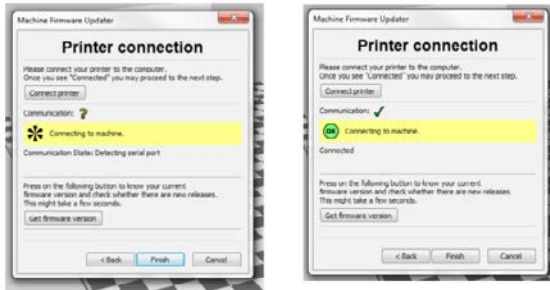

7. After the printer is connected, click on Get Firmware Version. This button compares the printer's version of the firmware with GitHub's latest version, and will display an update option if a new version is available.



8. The new version will start to download, and when it is completed an Assistant will open displaying a folder called Compiled Firmware. Open this folder, and then select and open a file called Marlin.hex.

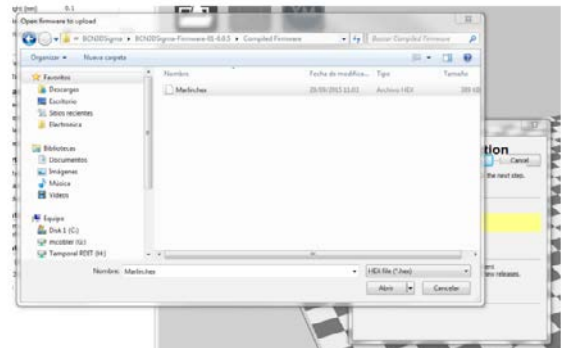
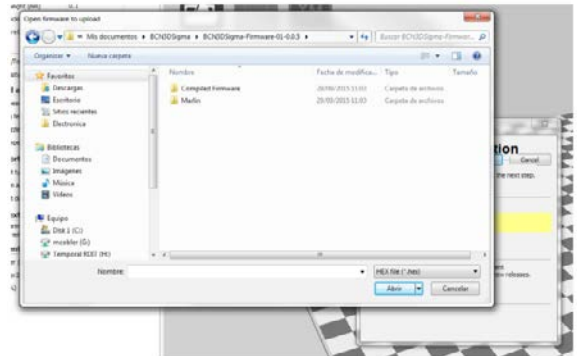

8. After you have opened it the firmware will start to update. You can follow the updating process on the green progress bar which fills from left to right.



# Functionalities

This section contains a description of BCN3D Sigma functionalities. The main menu is divided into two large groups: printing and utilities. The first covers all the standard printing functions, while the second includes functions such as calibration, maintenance, settings, etc.

## Printing

Located on the left-hand side of the main menu, this starts the printing process. You can control some of the parameters of the settings while the object is being printed from here.

**Select object:** when you access the printing function a screen appears with the name of the object you have selected. If you want to change the object, use the onscreen arrows to select a new object, and then click on the selected file to confirm your selection.

**Print:** this screen displays the progress of the printing process. Press the Pause button to move the extruders away from the object and stop the printing process. If you do this a Play button will appear to restart the process. The Stop button cancels the printing process and takes you back to the main menu.

**Settings:** this option allows you to modify the printing speed and temperatures. When you select the element that you want to adjust, the objective temperature/speed value appears, and you can adjust them by using the side buttons. The Back button in the top left-hand corner will take you back to the printing screen.

## Utilities

This is situated on the right-hand side of the main menu, and allows you to adjust temperatures, calibrate, insert or remove filaments, purge, etc.

**Temperature:** this menu allows you to pre-adjust the

## Functionalities

temperature by selecting the PREHEAT option. You can adjust the temperature (raise or lower) of the two hot-ends and the printing surface. The COOLDOWN option lowers the temperature of the extruders and the heated bed to room temperature.

**Filament:** this menu allows you to load the filaments into the printer. The menu functions are:

### Insert

This is for loading filament into one of the extruders. You should first select the side where you want to load the filament. Next, you should insert the filament into the extruder following the onscreen instructions (the extruder should first reach the right temperature, which may take a few minutes). Once you have inserted the filament the extruder can be adjusted slightly to allow you to load the rest of the filament. When purging we recommend you pull out a generous amount of filament to ensure the extruder is purged correctly.

### Remove

This operation is the opposite of the operation described above, although it is performed in a similar way. After you have selected which side you want to remove the filament from, wait until the hot-end has reached the right temperature and then remove the filament.

### Purge

This menu allows you to control the temperature of the two hot-ends, and extract or dislodge clogged filament. In order to be able to move the filament, the temperature difference between the objective temperature (under the thermometer) and the actual temperature (under the extruder icon) should be less than 5° C. Use the central button to choose the extruder.

**Calibrate:** this menu allows you to calibrate the BCN3D Sigma printer's surface and extruders. This process should be performed when components are replaced, and during standard printer maintenance (described in this manual).

### Bed calibration

this option allows you to level the printing surface. The process is performed by an onscreen self-test run by the printer, followed by instructions to correct the position. The screen displays how many turns (in eighths of a turn) each of the levelling wheels should be turned, and in which direction.

### Full calibration

this option allows you to perform a full calibration, where the heated bed and the relative positions of the extruders are calibrated. You will be guided by onscreen instructions, and the aim is to select the best of the different test prints performed by the printer.

# Filament

The BCN3D Sigma printer gives the best printing results with PLA and ABS from Colorfila in a 3 mm plastic filament format, although it accepts many other materials.

A brief description of the materials currently used by the printer is given below:

## PLA

PLA (polylactic acid) is by far and away the best material for 3D printing, since it is easy to shape using FFF. This is the recommended option when you first start 3D printing, and is suitable for the printing requirements of the majority of applications in most cases. It comes in a wide range of colours, and will allow you to print complex shapes easily. The finish is slightly glossy or semi-matte.

When printing the operating temperature oscillates from between 195° C to 220° C, depending on the supplier and printing speed. Printing overhangs is easier if a layer fan is used. It has a very high adhesion to the printing surface, and if the temperature of the heating bed is 45° C - 55° C no other adhesion product is required, although it's recommended.

It has average mechanical properties, although it becomes slightly brittle when printing irregularly-shaped objects. At operating temperatures of 50° C or more, the mechanical properties and rigidity of the objects may decrease. It dissolves in caustic soda.

## ABS

ABS (acrylonitrile butadiene styrene) is one of the most widely used materials in 3D printing, and is more suitable for some types of printing than PLA. Printing with ABS is more complex, and requires a certain amount of care: it is not recommended for non-experienced users. It comes in a very wide range of colours, and the finish is semi-matte or matte.

## Filament

ABS is printed at temperatures of between 210° C and 240° C, depending on the supplier and the printing speed. ABS performs better with overhangs than PLA and needs less air from the layer fan (too much air is usually harmful). Its base does not adhere to the surface as well as those of PLA objects, as it contracts when cooling down, which means it usually requires an adhesive lacquer even when the temperature of the printing surface is 70° C.

It has higher mechanical properties than PLA, and is more stable at high temperatures. If the object has a very large base, the adhesion problems become worse, in particular with the edges of the object.

### PVA

PVA (polyvinyl alcohol) is a material which is only used to print support structures for overhangs. It is a linen white colour and soluble in water, which means it can be removed easily and safely, and prints at around 190° C, which is a lower temperature than PLA. Problems may occur when printing the supports due to oozing issues.

The material is highly sensitive to ambient moisture, and must be removed from the printer after use and stored in a dry place.

### TPE

TPE (thermoplastic elastomer) is a flexible material which is available in a range of colours. Printing with TPE is more complex, and requires a certain amount of care. It is not recommended for non-experienced users. The recommended nozzle size is 0.6 mm. It is a plastic which is highly sensitive to ambient moisture, and should be stored in a dry place when not being used.

### HIPS

HIPS is a material with properties similar to those of ABS, but which reacts with and dissolves in Limonene. It is usually used to create support structures when printing with ABS.

### LAYBRICK

Laybrick is a plastic-based material which imitates stone finishes, and has similar extrusion characteristics as PLA. 0.6 mm nozzles should be used due to the size of its particles. It is not recommended for non-experienced users.

### LAYWOO

Laywoo is another plastic-based material which imitates wood finishes. 0.6 mm nozzles should be used due to the size of its particles. It is not recommended for non-experienced users.

# Maintenance Plan

We recommend you carry out the maintenance procedures described in the table below in order to keep your printer running optimally. The procedures are grouped depending on frequency they should be performed is shown on the right.

<b>FREQUENCY</b>	<b>ACTION TO PERFORM</b>
<b>Daily</b>	Keep the printer free of dust and in a dry, cool place
	Storage the spools in a dry, cool place
	Remove the filament inside the Purge Tank
	Remove the filament leftovers spread inside the printer
<b>Weekly</b>	Clean the Printing Surface
	Clean the nozzles
	Level the Printing Surface (also after a transportation)
<b>Monthly</b>	Clean fans dust
	Full calibration (also after a transportation or replacing a hotend)
	Clean X/Y linear guides using a cloth
	Clean Z bars using a cloth
	Lubricate X/Y linear guides using sewing machine oil
	Grease Z leadscrew using industrial multipurpose grease.
Check firmware updates	
<b>Quarterly</b>	Check bolted and threaded joints
	Check tension of extruder springs
	Check X/Y belt tension
	Check connections of moving cables

# BCN3D Technologies

## Technical Assistance Services

If you do not find a solution to your problem in this manual, please contact the BCN3D Technologies team through any of the following channels:

### Forum

We recommend that you visit our forum before taking any other action. It is very likely that another user has had the same problem as you, and the forum is where most of them are solved.

[www.bcn3dtechnologies.com/es/forum](http://www.bcn3dtechnologies.com/es/forum)

### Technical Assistance

You can contact the technical assistance services by email, and we will answer you as quickly as possible. Please remember to include your phone number so we can contact you.

[sat@bcn3dtechnologies.com](mailto:sat@bcn3dtechnologies.com)

### Email

If you have a question that is not related to technical assistance, please send us an email to the address below. A BCN3D Technologies expert will contact you as quickly as possible.

[info@bcn3dtechnologies.com](mailto:info@bcn3dtechnologies.com)

### Telephone

We have a helpline for situations that cannot be dealt with through the other channels:

**93 413 70 88**

You can find all of this information in the Contact Section of our website:

[www.bcn3dtechnologies.com/es/contact](http://www.bcn3dtechnologies.com/es/contact)

Be sure to include the serial number of your computer whenever you send us a query to help us provide the best possible services.

# Diagram of BCN3D Sigma

- 1 Teflon tube
- 2 Extruder
- 3 Hot-end cable
- 4 Spool mount
- 5 Hot-end
- 6 Purge chamber
- 7 Printing surface
- 8 SD reader
- 9 Touchscreen
- 10 Filament input hole
- 11 Plastic Spool
- 12 Switch
- 13 Platform
- 14 Power supply socket
- 15 USB port

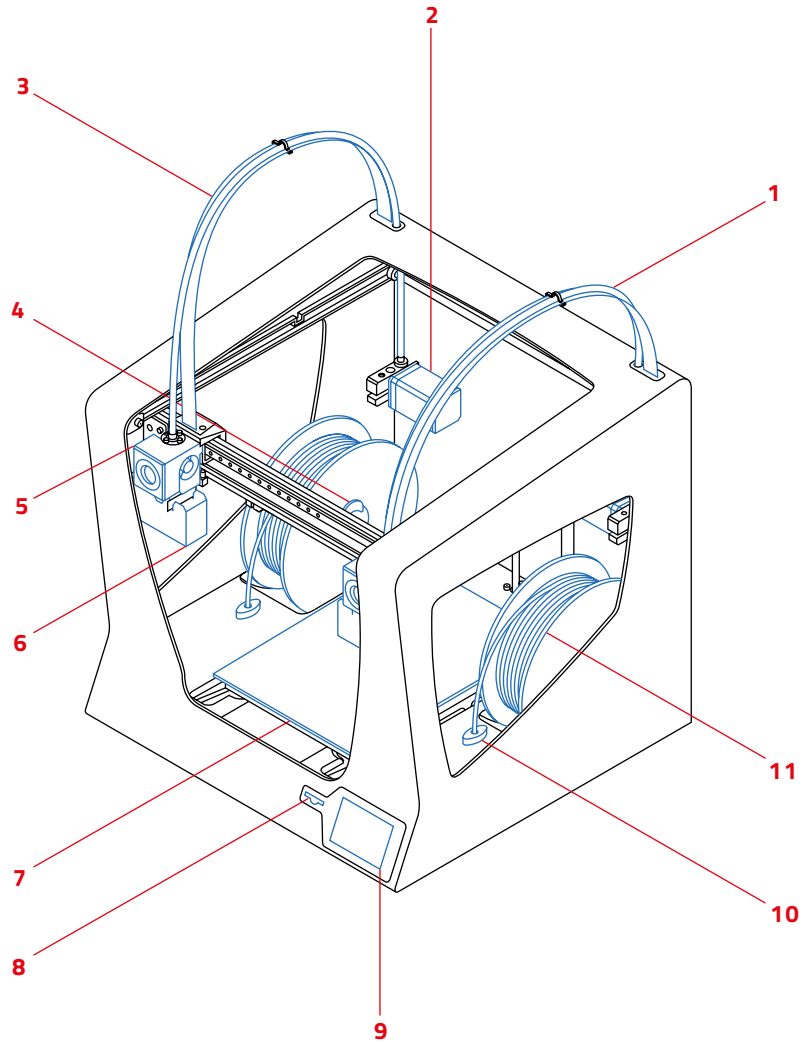

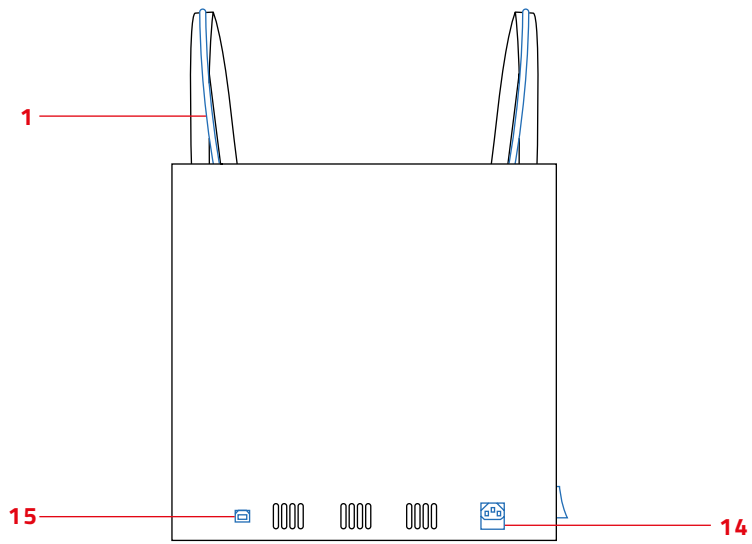
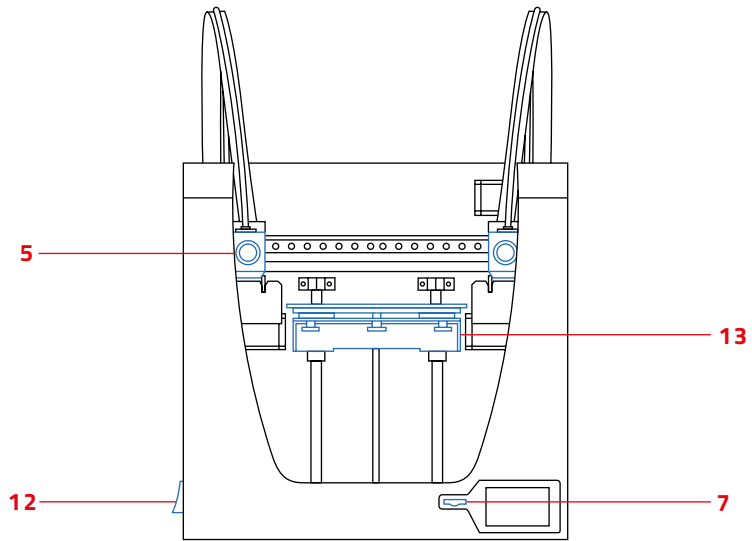

# Warranty, returns and replacement policy

All BCN3D Sigma components have a two-year warranty, provided that the defects are manufacturing defects and at no time have the components been misused. Replacement parts and/or technical services will be provided for components that have proven manufacturing defects. In this case we will do everything we can to help you get your printer working again.

Returns will only be accepted for products that have not been used within a period of 14 business days, starting from when the printer was delivered. Once this period has expired, all sales will be considered to be final. "Not used" is understood to mean products that have never been assembled, switched on, programmed or altered in any other way.

# Terms and conditions of service

The information in this manual is subject to change at any time without notice, and is provided solely for informational purposes. BCN3D Technologies reserves the right to change or modify the manual at any time at its sole discretion, and you agree to be bound by any such changes and/or modifications. If you would like to get the most up-to-date information, please contact BCN3D Technologies' technical team or visit the [www.bcn3dtechnologies.com/es/forum](http://www.bcn3dtechnologies.com/es/forum) on our website.

The design of this manual and all the text, graphics, information, content and other materials are protected by copyright and other laws. Some of the trademarks, trade names, service marks and logotypes (the "Trademarks") used are registered and unregistered trademarks, trade names and services marks that are the property of BCN3D Technologies and its partners. Nothing contained in this manual grants or should be construed as granting, by implication, estoppel, or otherwise, any license or right to use any Trademark without the written permission of BCN3D Technologies. Any unauthorised use of the information, materials or trademarks may breach the laws regulating copyright, registered trademarks, privacy and publicity and/or other laws and regulations.

# Open source

Open source is a development model that promotes universal access by granting software licenses free of charge, and also universal distribution, including subsequent improvements.

We believe that adopting an open source philosophy offers many advantages:

- **More control:** We can see everything that is happening with the source code, designs etc., and modify them to suit our needs.
- **It helps us learn:** We can see and read the software designs that other people have made, which helps us to become better programmers and engineers.
- **Safety:** Since the designs are open designs, a lot more people can modify and/or correct any errors that the original programmer may have made.
- **Making improvements quickly:** The open source community provides a lot of information about how to improve the product. This helps us to fix errors and update programmes much more quickly.

Using open source licenses for the products we develop is a way of expressing our willingness to share, to collaborate with other people in a transparent way (so that others can see what we are doing and join in), to embrace failure as a means of improving, and to expect, even encourage, everyone else to do the same.

BCN3D Technologies and its products would not be where they are today without the RepRap project and its open source community. The RepRap project started out as an initiative whose objective was to develop a 3D printer which could print most of its own components and be a low-cost printer. As an open source project, all of the designs produced by the project have been released under a free software General Public License (GPL).

This project does not only include hardware, but has been conceived as a complete ecosystem of tools for printing, from the CAD/CAM software to the code read by the machine to print physical objects.

BCN3D Sigma printers use many open source tools and technologies, such as Marlin software and the Cura pre-processed software. The first controls all the printer's components, while the second converts the 3D file into G-code, a language the machine is able to understand.

Marlin firmware is published under a GPL license. This means that we must keep Marlin open, and must provide our source code to end users. For this reason we have our repository on the Github platform, where we post all the changes we make.

Cura software is published under an AGPLv3 license. This is the same as the GPLv3 general license but a paragraph has been added to Section 13 which makes it obligatory to provide source code to those who use software through a network. We therefore have repositories for each operating system so that users can access the source code.

Open Source is not only used for code, but also covers hardware. In our case all the mechanical and electronic parts are published under a GPLv3 license.

BCN3D Technologies is firmly committed to open source initiatives, and we believe that with the help of the community we will be able to make better products.

